

# SIMMONS

ELECTRONIC DRUM KIT WITH MESH HEADS



# TITAN 90

OWNER'S MANUAL

[SimmonsDrums.net](http://SimmonsDrums.net)

# SAFETY INSTRUCTIONS

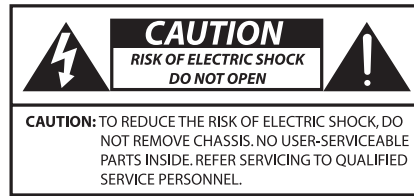

AVIS: RISQUE DE CHOC ELECTRIQUE-NE PAS OUVRIR.



THE LIGHTNING FLASH WITH ARROWHEAD SYMBOL WITHIN AN EQUILATERAL TRIANGLE IS INTENDED TO ALERT THE USER TO THE PRESENCE OF UNINSULATED DANGEROUS VOLTAGE WITHIN THE PRODUCT'S ENCLOSURE THAT MAY BE OF SUFFICIENT MAGNITUDE TO CONSTITUTE A RISK OF ELECTRIC SHOCK TO PERSONS.



THE EXCLAMATION POINT WITHIN AN EQUILATERAL TRIANGLE IS INTENDED TO ALERT THE USER TO THE PRESENCE OF IMPORTANT OPERATING AND MAINTENANCE (SERVICING) INSTRUCTIONS IN THE LITERATURE ACCOMPANYING THE PRODUCT.



APPARATUS SHALL NOT BE EXPOSED TO DRIPPING OR SPLASHING, AND NO OBJECTS FILLED WITH LIQUIDS, SUCH AS VASES, SHALL BE PLACED ON THE APPARATUS.

1. Read these instructions.
2. Keep these instructions.
3. Heed all warnings.
4. Follow all instructions.
5. Do not use this apparatus near water.
6. Clean only with dry cloth.
7. Do not block any ventilation openings. Install in accordance with the manufacturer's instructions.
8. Do not install near the heat sources, such as radiators, heat registers, stoves or other apparatus (including amplifiers) that produce heat.
9. Do not defeat the safety purpose of the polarized or grounding-type plug. A polarized plug has two blades, with one wider than the other. A grounding-type plug has two blades and a third grounding prong. The wide blade or the third prong are provided for your safety. If the provided plug does not fit into your outlet, consult an electrician for replacement of the obsolete outlet.
10. Protect the power cord from being walked on or pinched, particularly at the plug's convenience receptacles and the point where they exit from the apparatus.
11. Only use attachments/accessories specified by the manufacturer.
12. Use only with the cart, stand, tripod, bracket or table specified by the manufacturer or sold with the apparatus. When a cart is used, use caution when moving the cart/apparatus combination to avoid injury from tipover (Figure1).
13. Unplug this apparatus during lightning storms or when unused for a long periods of time.
14. Refer all servicing to qualified service personnel. Servicing is required when the apparatus has been damaged in any way, such as power supply cord or plug is damaged, liquid has been spilled or objects have fallen into the apparatus, the apparatus has been exposed to rain or moisture, does not operate normally or has been dropped.



Figure 1

**WARNING:** To reduce the risk of fire or electric shock, do not expose this apparatus to rain or moisture.

Do not expose apparatus to dripping or splashing and do not place objects filled with liquids on the apparatus.

# CONGRATULATIONS!

...on your purchase of this **Simmons Titan 90** Electronic Drum Kit. To get the most enjoyment from this kit, we recommend that you skim through this manual at least once, then refer back to it to learn more about specific functions.

## CARING FOR YOUR TITAN 90 ELECTRONIC DRUM SET

### LOCATION

- Keep the drum kit away from direct sunlight, high-temperature sources and excessive humidity to prevent deformation, discoloration or more serious damage.

### POWER SUPPLY

- Turn the power switch OFF when the Titan 90 is not in use.
- The AC adapter should be unplugged from the AC outlet if the Titan 90 is not to be used for an extended period of time.
- Avoid plugging the AC adapter into an AC outlet that is also powering high-consumption appliances, such as electric heaters or televisions. Also avoid using multi-plug adapters, since these can reduce sound quality, cause operation errors and result in possible damage.
- To avoid damaging the unit, turn the Titan 90 and all related devices OFF prior to connecting or disconnecting cables.

### HANDLING AND TRANSPORT

- Never apply excessive force to controls, connectors and other parts.
- Unplug cables by gripping the plug firmly. Do not pull on the cable.
- Disconnect all cables before moving the module.
- Physical shocks caused by dropping, bumping or placing heavy objects on the module can result in scratches and more serious damage.

### CLEANING

- Clean the module with a dry, soft cloth.
- A slightly damp cloth may be used to remove stubborn grime and dirt.
- Never use cleaners such as alcohol or thinner.
- To avoid discoloration, do not place vinyl objects on top of module.

### ELECTRICAL INTERFERENCE

- The module contains digital circuitry and may cause interference if placed too close to radio or television receivers. If this occurs, move the Titan 90 farther away from the affected equipment.

### SERVICE AND MODIFICATION

- There are no user serviceable parts in the drum module.
- Do not attempt to open the sound module or make any change in the circuits or parts of the unit. This would void the warranty.

# TABLE OF CONTENTS

SAFETY INSTRUCTIONS.....	2	SONG MODE	
CONGRATULATIONS .....	3	Playing a Song.....	25
CARING FOR YOUR TITAN 90 ELECTRONIC DRUM SET ...	3	Muting the Drum Part.....	25
FINAL ASSEMBLED KIT.....	5	Changing the Drum Mix.....	25
FEATURES .....	6	Changing the Tempo of a Song .....	25
ASSEMBLING YOUR KIT.....	7	Copying a Song .....	25
CONNECTIONS		RECORDING A SONG	
Connecting the Module and Pads.....	10	To Record .....	26
AC Adapter.....	11	PRACTICE MODE	
Connecting Audio Equipment .....	12	To Use Practice Mode .....	27
Aux Input.....	12	Practice Mode Edit.....	27
Connecting MIDI Devices and Computers.....	13	To Select Between the 6 Practice Modes.....	28
Bluetooth Wireless Audio and MIDI .....	13	SETUP MODE	
USB Audio and MIDI Connection.....	13	Trigger Settings .....	29
Tablet Shelf .....	13	MIDI Parameters .....	30
TITAN 90 DRUM MODULE OPERATION		Hi-Hat .....	30
Top Panel .....	15	Utility .....	31
Bottom Panel.....	16	MIDI Note Defaults.....	32
Back Panel .....	16	Hi-Hat MIDI Settings .....	32
Side Panel.....	16	USB Operations.....	32
QUICK START OPERATIONS		BLUETOOTH	
Turning the Power on the Module.....	17	Bluetooth Wireless MIDI .....	33
Basic Operation and Navigation .....	17	Bluetooth Wireless Audio .....	33
Adjusting Values .....	17	Simmons Drums 2 App for iOS and Android .....	33
KIT MODE		APPENDIX	
Selecting a Kit .....	18	Sound List .....	34
Using the Metronome (Click) .....	18	Kit List .....	44
KIT MODE - ADVANCED		Song List .....	45
Editing a Drum Sound .....	19	MIDI Implementation Charts .....	46
Multi Edit.....	19	Warranty.....	47
Zone Edit.....	20	Customer Service.....	48
Pitch Edit.....	20		
Filter Edit.....	20		
Sample Edit.....	21		
Adjusting EQ and Adding Effects .....	22		
Editing the Kit Mix.....	23		
Saving and Naming a Kit .....	24		
Factory Reset.....	24		

# FINAL ASSEMBLED KIT



*NOTE: Hi-Hat Stand and Kick Pedal are not included.*

# FEATURES

## TITAN 90 SOUND MODULE GENERAL FEATURES

### POLYPHONY

- Voices - 64

### SOUND

- Drum Voices - 672
- Drum Kits - 75 Preset/25 User
- Songs - 3 Preset/7 User

### EFFECTS

- Reverb: Hall1, Hall2, Room1, Room2, Room3, Stage1, Stage2, Plate, Delay, Echo, Off
- Compressor: Easy, Grind, Roomy, Pummel, Stomp, Spank, Pump, Nuke, Kit, Off

### TRIGGER INPUTS

- 25-Pin Multi-Trigger Input
- EXP 1 and EXP 2 Dual-Zone Inputs

### EXTERNAL CONNECTIONS

- 1/8" Headphone Output
- 1/4" Line Outputs (Left/Mono and, Right)
- 1/8" TRS AUX Input with Level Control
- USB-C Connection for MIDI Output via computer for audio/MIDI input and output to computer or mobile device
- USB-A Connection for Hosting (USB Flash Drive)
- Bluetooth Wireless Audio and MIDI

### SEQUENCER

- Preset Songs - 3
- User Songs - 7
- Tempo - 20-280 BPM
- Click/Metronome - Time Signature, Tempo

### POWER

- 9V, 600mA, Center-Positive

### OTHER HARDWARE

- Drum Rack and Mounts
- 7" Kick Drum Pad
- 12" Multi-Zone Snare Mesh Drum
- Snare Stand
- 10" Dual-Zone Tom Mesh Drums (x4)
- 12" Triple-Zone Moving Hi-Hat Pad with Control Module
- 12" Triple-Zone Crash Cymbal Pad with Choke (x2)
- 14" Triple-Zone Ride Cymbal Pad with Choke

# ASSEMBLING YOUR KIT

## INSIDE THIS PACKAGE

Before assembly, please make sure all the items listed below are present.

### Cymbals



### Drum Pads

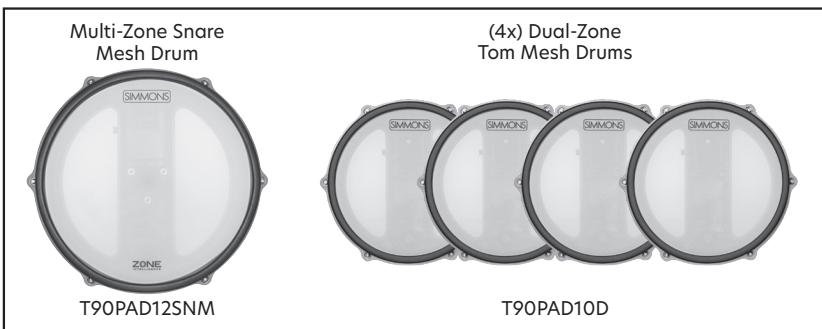

### Drum Rack

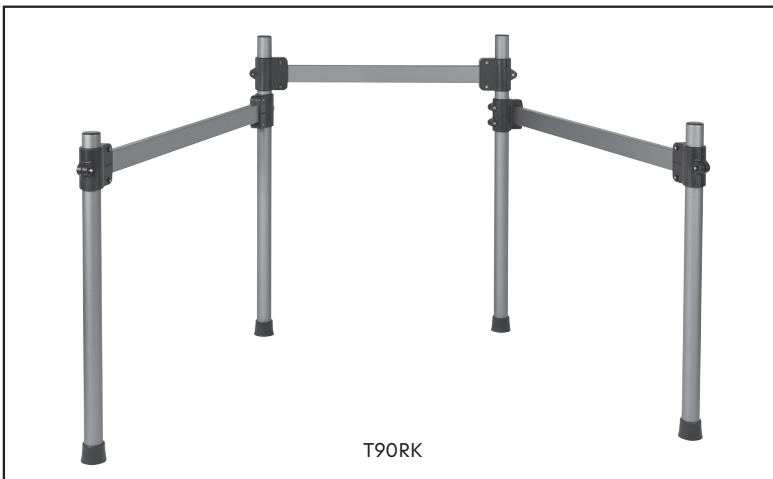

### Drum Module & Tablet Shelf



### Accessories

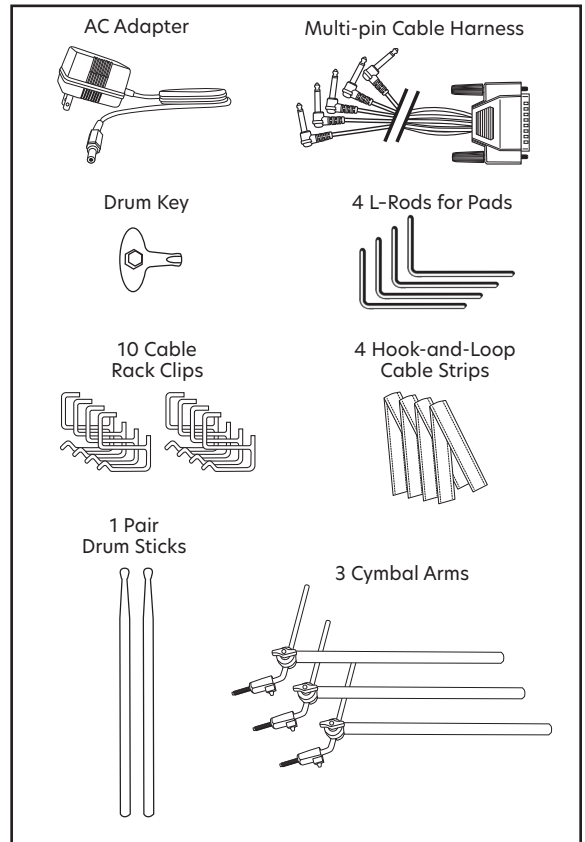

### Kick Drum Pedal



### Snare Stand



NOTE: Hi-Hat Stand and Kick Pedal are not included.

# ASSEMBLING YOUR KIT

## Rack Assembly - Titan 90

1. Remove all rack arms and legs from the box and lay them out on the floor.
2. Identify the center bar (rectangular bar with the Simmons logo). This bar connects the two taller vertical posts.
3. Orient the center bar so the Simmons logo faces outward.
4. Identify the two tall vertical posts:
  - The right vertical post has a pass-through bracket.
  - The left vertical post has two identical T-brackets.
5. Insert the center bar into the top T-bracket of each vertical post, forming the main rack crossbar.
6. Identify the left arm, which has two mounts attached (a module mount and a cymbal mount). The drum mounts should face away from you.
7. Attach the left arm to the bottom T-bracket of the left vertical post, with the cymbal mount positioned closer to the vertical post.
8. Attach the outer left leg to the open end of the left arm.
9. Identify the right arm and slide it through the pass-through bracket on the right vertical post, with the cymbal mount positioned closest to the vertical post.
10. Attach the outer right leg to the open end of the right arm.



*NOTE 1: We recommend putting the Titan 90 on a drum rug to keep the components together.*

*NOTE 2: The right-side bar has a pass-through clamp, designed to make the rack expandable. You can make this arm shorter when you assemble the kit to save space. .*



Scan this QR code  
for a kit assembly  
tutorial video.

## ASSEMBLING YOUR KIT

### ATTACHING THE CYMBAL PADS

1. Insert the three cymbal arms into the flat rack clamps facing behind the rack.
2. Remove top wing nut and felt from cymbal arm. Place cymbal pad on the cymbal arm.
3. Reattach the felt washer and wing nut. Tighten wing nut.

*NOTE: If you want the cymbal pads closer, you can angle the bottom section from the clamp and use the "boom" joint to make the cymbal flat or any angle you want.*



### ATTACHING THE DRUM MODULE AND DRUMS

1. Loosen wing screws on the tom drum clamps.
2. Place the L-rods into the opening of the drum clamps as shown in the image above. The shorter end of the L-rod goes into the clamp and the longer end faces the drummer.
3. Slide the drum pads onto the L-rods. The four 10" tom pads go on the four clamps.
4. Loosen the module clamp, the one farthest to the drummer's left. Insert the module into the clamp and tighten.
5. Attach the shelf for your mobile phone or tablet to the module if desired.



### BASS DRUM AND SNARE

1. Connect a kick drum pedal of your choice to the front of the kick drum pad. There is a metal lip on the front of the kick pad that most kick pedals will be able to attach to.
2. Place the kick drum pad on the floor in the center of the rack as illustrated.
3. Open and loosen the snare stand, placing it adjacent to the kick drum.
4. Place the 12" snare pad on the snare stand and tighten so that the pad is locked into place.



### MOVING HI-HAT

1. Remove the clutch from a hi-hat stand of your choice.
2. Slide the moving hi-hat module over the pull arm so that the module rests on the stand seat, with the attached clutch on top.
3. Tighten the attached clutch to the desired height on the pull arm.
4. Place the hi-hat stand left of the snare stand as illustrated.

U.S. Patent No. 12,254,856 and other patents pending.

# CONNECTIONS

## CONNECTING THE SOUND MODULE AND PADS

**CAUTION!**

To prevent electric shock and damage to the device, make sure the power on the sound module and all related devices is switched to OFF before making any connection.

Using the provided cables, connect the 1/4" jacks to the corresponding drum pads, cymbal pads and kick pad. The 25-pin connector will attach to the multi-pin connector serial port on the bottom of the sound module. (See illustration below)

The sound of the hi-hat is controlled by the sensor under the hi-hat. Place the hi-hat and controller on your hi-hat stand, then tighten the clutch. The sound defaults to open hi-hat. Step on the pedal to get a closed hi-hat sound.

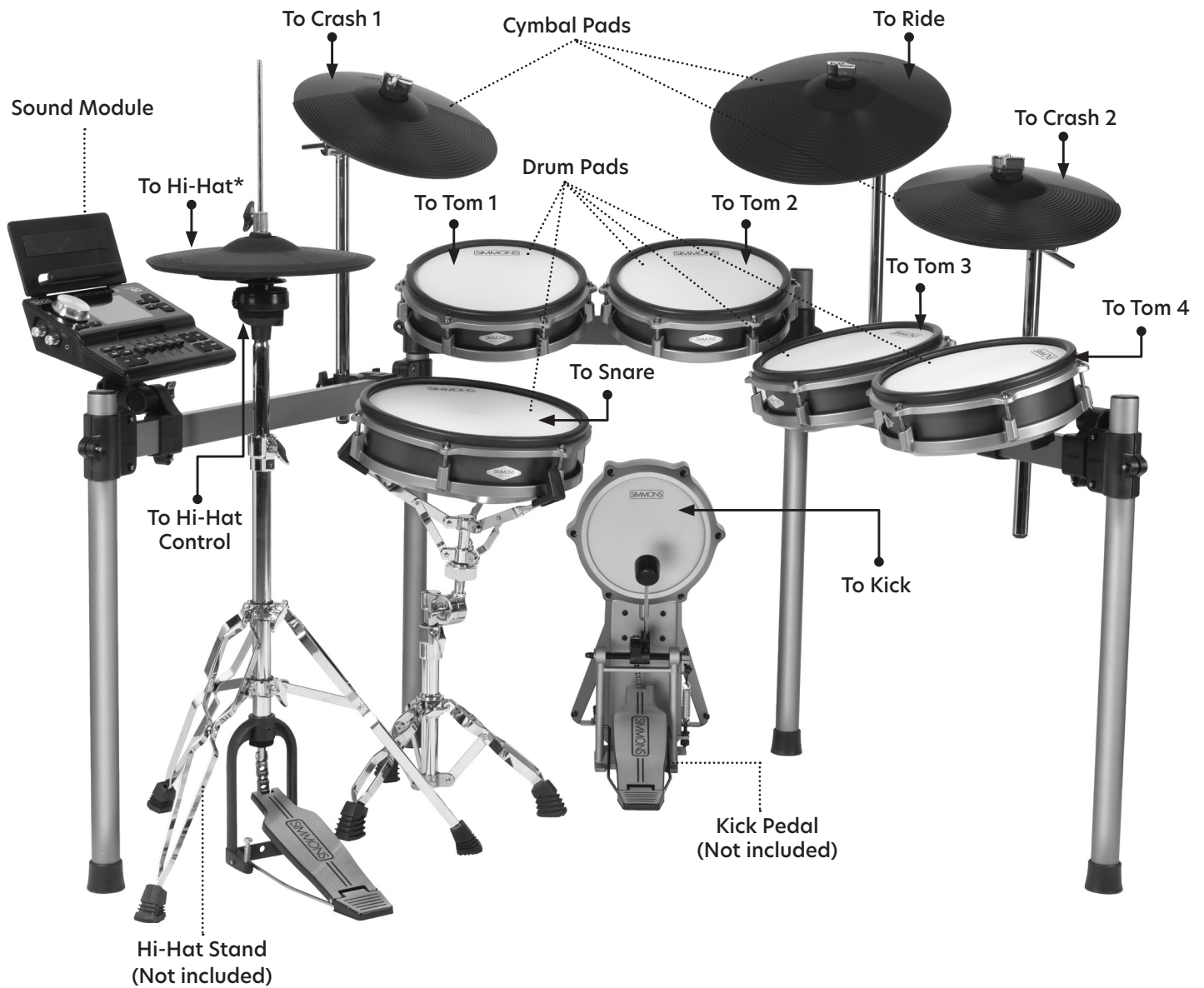

\*U.S. Patent No. 12,254,856 and other patents pending.

## CONNECTIONS

### CONNECTING THE SOUND MODULE AND PADS

Using the provided cables, connect the 1/4" jacks to the corresponding drum pads, cymbal pads and kick pad. The pin connection will attach to the serial port of the sound module (see illustration). The cables have some extra length so you can customize the kit—for example swapping the crash and ride for left-handed players.



**NOTE:** Use the included cable clips to attach cables to the back of the rack and the hook-and-loop ties to attach cables secure them to the vertical sections of the rack.

### AC ADAPTER

The Titan 90 module uses an external power supply called an AC adapter external power supply. This plugs into the back of the module.

Connect the power adapter with the 9V jack on the rear panel. For extra protection, there is a cable clip for the power cable on the bottom of the module. Insert the power cable through the C-shaped opening.

**NOTE:** To protect the speakers, amplifier and the drum module from damage, lower the volume to the minimum level before switching the power ON.

Make sure the power is switched OFF when connecting the drum module to external devices.

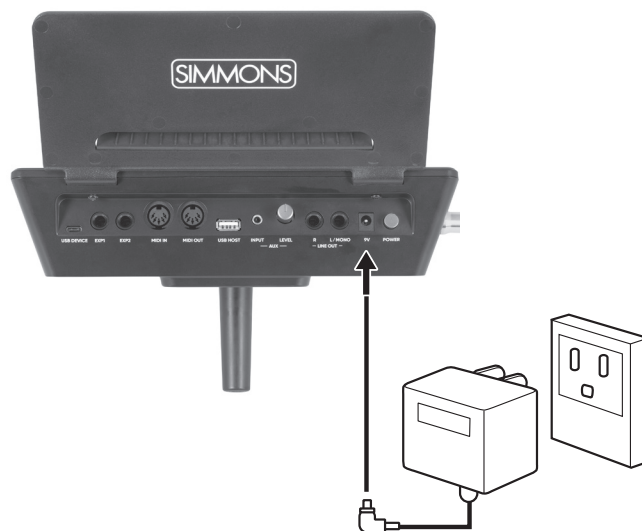

# CONNECTIONS

## CONNECTING AUDIO EQUIPMENT

### Mixers and Amplifiers

1. To listen to the module, send the outputs to a mixer or drum amplifier. Connect the Output L/MONO and R jacks on the rear panel to your amp. For monaural playback, only use the L/MONO jack; for stereo playback, connect both L/MONO and R jacks.
2. The volume from the module is adjusted with the VOLUME knob. This controls both the line outputs and the headphone output volume.
3. You can connect a standard pair of headphones to the Titan 90 module to listen to your electronic drum set without disturbing others. Connect the headphones to the 1/8" headphone jack located on the left side of the drum module. Adjust the volume to a comfortable level to avoid damaging your hearing.



### AUX INPUT

This input allows you to mix the input from external audio sources with the Titan 90 module's internal sounds.

1. Plug the audio output of your smartphone, tablet or other audio source into the AUX IN jack on the back panel.



## CONNECTIONS

### CONNECTING MIDI DEVICES AND COMPUTERS

MIDI stands for Musical Instrument Digital Interface, which is a worldwide standard communication interface that enables electronic musical instruments and computers (of all brands) to communicate with each other. MIDI sends note and other communication between devices. This exchange of information makes it possible to create a system of MIDI instruments and devices that offer greater versatility and control than is available with isolated instruments. Whether you interface with computers, sequencers, expanders or other controllers, your musical horizons will be greatly enhanced.

### BLUETOOTH WIRELESS AUDIO AND MIDI

The Titan 90 includes Bluetooth wireless audio and MIDI for connection to apps like the Simmons Drum App for iOS and Android. See page 29 for connection instructions.

### USB AUDIO AND MIDI CONNECTION

The USB Device jack allows you to connect the module directly to your computer. It can be connected without driver installation under the Windows & macOS environment. The module will be recognized to receive and transmit audio and MIDI messages through a single USB cable. The Titan 90 module will appear as "Titan 90 assume it's correct here" in the USB device options of your software (see page 28 for more information).

*NOTE: When the USB is connected to a computer, all MIDI messages will be received and transmitted via USB.*

### TABLET SHELF

The Titan 90 includes a smartphone and tablet shelf. Press this shelf into the slots on the back of the module until you feel a click. You can rest your device here and rubber padding keeps it from moving too much. Excessive playing will vibrate the shelf, however, so keep an eye on your device when thrashing the drums. You can also put this manual or music notation on the shelf.



# TITAN 90 DRUM MODULE OPERATION

## TOP PANEL



# TITAN 90 DRUM MODULE OPERATION

## TOP PANEL

1. LCD Display: This display shows any information you need to know about the drum kit.
2. Page Buttons: Select pages displayed at the top of the LCD Display within EDIT, SONG, MIX, FX and Setup Modes.
3. Value Knob: Quickly changes kits, songs or values in menus.
4. + and - Buttons: Precisely change kits, songs or values in menus.
5. Click: Turn the Metronome on or off.
6. Tempo: Press Tempo then + or - to change the tempo of the song or metronome. You can also tap the tempo button to the rhythm you want to set it to automatically.
7. Mute: In SONG mode, press this button to mute the drums so you can play along with the backing tracks.
8. Save: Press to save your drum kit edits to a User Kit.
9. Play: Press once to start song playback. Press a second time to stop playback.
10. Rec: Press to begin recording your own song to the User Song as a MIDI performance.
11. Faders: Change values displayed at the bottom of the LED Display within KIT, SONG, MIX, EDIT and FX Modes. Note: Fader positions may not accurately reflect the values displayed on the screen when accessing a new mode.
12. Mix: In KIT Mode, press this button to change the level, pan and send for each part of the drum kit. In SONG Mode, press this button to change the balance between the drum sounds and the backing tracks.
13. Edit: In KIT Mode, press this to change drum sounds and drum sound parameters. In SONG or PRACTICE Mode, press this to change the song settings. To access more parameters for editing, keep pressing this button. Press KIT or SONG to exit this Edit Mode.
14. FX: Press this to change the EQ and select Reverb and Compression type and values.
15. Setup: Press this button to change global settings like trigger sensitivity, MIDI, Hi-Hat usage, Bluetooth and other Utility Options.
16. Kit: Press this to exit out of menus and back to the main screen of the module, KIT Mode. Cycle through various preloaded kits and user-defined kits.
17. Song: Press to access SONG Mode to play the preset and user songs.
18. Cursor Buttons: Use these buttons to cursor through parameters and values in SONG, EDIT and SETUP Modes.
19. Bluetooth Indicator: When a device is connected to the module over Bluetooth, this LED will light up blue.

# TITAN 90 DRUM MODULE OPERATION

## BOTTOM PANEL

1. 25-pin connection jack for the pad trigger cables.



## BACK PANEL

1. USB Device: USB-C jack used to connect to computer for audio and MIDI in and out.
2. EXP1 and EXP2: Used to connect additional dual-zone pads.
3. MIDI IN and OUT: Connect to equipment that accepts a 5-pin DIN MIDI output.
4. USB Host: USB-A jack used to connect flash drive to load samples.
5. AUX Input: 1/8" jack to send audio to be played through the module.
6. AUX Level: Used to control the volume of the audio played by Aux Input.
7. Left/Mono and Right: Line outputs to connect to a sound system or drum monitor. If you only plug into the Left/Mono output, it will include both left and right signals over one cable.
8. Power: Connect the included power adapter (9V/600mA, center positive). Press button to turn module on and off.
9. Tablet/Smartphone Shelf: Holds a tablet or smartphone so you can play along with music and videos or use apps. Rubber padding on the shelf keeps devices from slipping off.



## SIDE PANEL

1. Output Volume Knob: Controls Line Out output volume.
2. Headphone Volume Knob: Controls Headphone Output volume.
3. Headphone Out: This 1/8" stereo output works with most consumer and professional headphones.



## QUICK START OPERATIONS

### TURNING THE POWER ON THE MODULE

1. Connect the AC adapter to the drum module.
2. Press the power switch on the back panel to turn on the module.

*NOTE: There is an automatic power off function that turns off the module when the kit is not being used for a certain period of time. The default setting is off. If this gets changed, you can reset this in the Utility Mode.*



### BASIC OPERATION AND NAVIGATION

There are 3 main modes for the module: KIT, SONG and SETUP. To enter these modes, press the corresponding buttons on the top panel of the module.



### ADJUSTING VALUES

1. Select the parameter to be adjusted. When you first turn on the module, Kit Number is selected for changes.
2. Adjust the value using the Value Knob or Value Buttons.



## KIT MODE

### SELECTING A KIT

1. Press the KIT button. The current Kit number and Kit name are displayed.
2. Press the +/- buttons or turn the value knob to select the 75 Preset or 25 User Kits.
3. You may change the level of each of Kick, Snare, Toms, Hat and Cymbals using the faders below the LED Screen.

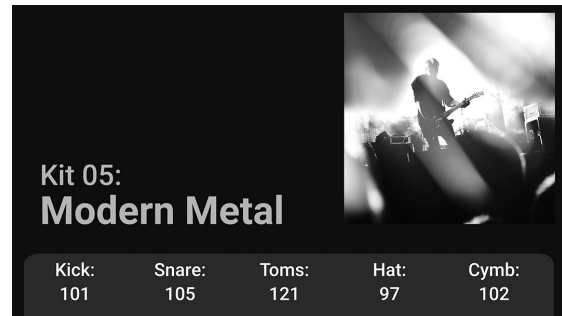

### USING THE METRONOME (CLICK)

The click is the metronome sound that is played when you are listening to play along with.

1. Press the CLICK button to switch the metronome on or off.
2. Press the TEMPO button to change the tempo using the + and - buttons or by turning the value knob.
3. To change the parameters of the metronome, press the SONG button and open the Metronome page by selecting the corresponding F-Key. Use the cursor buttons to select which parameter to edit, and use the value knob or +/- buttons to adjust values.
4. When the click is active, you will see the display animate the metronome back and forth to the tempo you set.

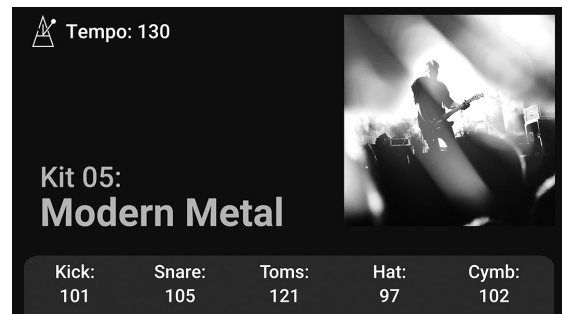

## KIT MODE - ADVANCED

### EDITING A DRUM SOUND

There are two types of drum editing on the Titan 90: Multi and Zone editing. Almost every pad on the Titan 90 has multiple zones. The ride cymbal has edge, bow and bell zones that each trigger a different sound. The hi-hat has nine zones. The snare has four. Zone Edit gives you the ability to change the sound, tuning, volume, etc. of one zone of a kit. Multi Edit changes all of the zones for that drum pad.

For example, you might like a drum kit except you want a different snare or crash cymbal. Multi Edit is a shortcut that changes all of the zones of that pad, instead of changing three or more zones individually.

### MULTI EDIT

As explained above, Multi Edit changes all zones of a drum pad. There are five types of Multi Edits: Kick, Snare, Tom, Hi-Hat and Cymbal. A Cymbal Multi can be assigned to the Ride, Crash 1 or Crash 2 pad. The others are dedicated to their specific pads. If you want one of the tom pads to be a second snare, you'll need to use Zone Edit to do that.

**Edit Pad:** This shows the pad selected for editing. Play a pad or cursor to this setting to change it.

**Multi Sound:** The default is "Current Tom Multi" or whichever pad is selected. That means it was programmed that way in the kit. Use the value dial or +/- buttons to change to a different sound. A "Kick Multi" is the same as the kick zone as there's only one zone.

**Tune:** Adjusts the tuning for all zones on this pad.

**Damp:** Adjusts the damping (or decay time) for all zones.

**Send:** The Reverb send for all zones.

**Level:** Adjusts the volume of all zones.

**Pan:** Changes the stereo position of all zones.

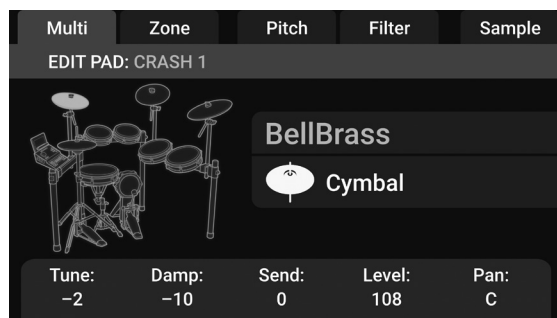

## KIT MODE - ADVANCED

### ZONE EDIT

Zone Edit changes each zone of a drum. For example, the snare has four zones: Center, Zone 2, Zone 3 and Rimshot. Each of those can have a different sound, tuning, damping and more.

**Edit Zone:** Select the zone for editing by playing a pad or cursoring up to this field.

**Drum Sound:** Sound assigned to the selected zone.

**Drum Category:** The category of drum sound. See the drum sound list at the end of this manual for a list of categories and sounds.

**Trig Sensitivity Offset:** This changes the sensitivity of the selected zone. For example, you might want the bow of the ride cymbal to have less sensitivity, but only for this drum kit. This allows you to change that sensitivity without changing it in Setup>Trigger, which changes it for all drum kits.

**Tune:** Adjusts the tuning for all zones on this zone.

**Damp:** Adjusts the damping (or decay time) for this zone.

**Send:** The Reverb send for this zone.

**Level:** Adjusts the volume of this zone.

**Pan:** Changes the stereo position of this zone.



### PITCH EDIT

Changes pitch setting for the selected zone.

**Pitch:** Changes the pitch up or down 12 semitones (one octave).

**Fine:** Finer control of the pitch.

**Vel>Pitch:** When active, heavier hits will cause the drum to raise its pitch. This can be useful on toms, world and electronic sounds. When this is active, you can't change the other two pitch settings.

### FILTER EDIT

Filter settings for the selected zone.

**Env Attack:** Changes the time before filtering starts.

**Vel>Decay:** Change the end of the envelope based on how hard you hit the pad.

**Vel>Cutoff:** Changes the lowpass filter (see below) by pad velocity. Try setting the cutoff to a negative value before bringing up this setting.

**Vel>Reso:** Changes resonance (see below) based on how hard you hit the pad.

**Cutoff:** Changes the low-pass filter frequency, which removes high frequencies.

**Reso:** Adds resonance to the filter for a synthetic sound.

## KIT MODE - ADVANCED

### SAMPLE EDIT

The Titan 90 can import up to 28MB of 16-bit WAV files. To move samples into the Titan 90, you will need to use the Simmons WAV Transfer software program (for macOS or Windows, available on [Simmonsdrums.net](http://Simmonsdrums.net)) or the Simmons Drums app (for iOS or Android, available on the App Store.) Plug your computer or mobile device into the "USB Device" jack of the module to transfer sounds. After transferring the sample(s) to the Titan 90's internal memory, you can assign the sample to a drum sound that can be played on the pads.

*NOTE: When new samples are loaded, the old samples are erased from memory.*

Once samples are loaded into the module, here is the process to assign one to a pad.

1. Open the Sample page of the Edit window by pressing the button above that tab.
2. Select an empty drum sound, like "Null 1."
3. Cursor down to the sample name field, at the top left in the columns below the sound name. Turn the value dial to select your sound.
4. Press SAVE. You can edit the name of the drum or leave it as it is. Press YES to confirm.
5. Press Edit and select Zone. Select or play a Drum Zone where you want to assign the new sound.
6. Cursor down the Zone Category and change it to User.
7. If necessary, cursor back up to select your drum sound.
8. You might want to save this kit to one of the User Kit locations.

There are some additional parameters in Sample Edit if you want multiple sounds assigned. You can layer up to four samples, or you can change between samples depending how hard the pad is hit. The columns from left to right:

Sample Name: Select the WAV file(s) you imported.

Vol/Pan: Change the volume and left/right panning for this layer.

Vel: This is the velocity range which this layer will play. The default is full range, 00 to 127.

Pitch: Change the pitch of this layer.

If you want sample A to play when you play the pad softly and sample B to play when you hit harder, set the top range of sample A to something like 80 and the bottom range of sample B to 81. Now when you play with a velocity between 0 and 80, you will hear sample A, from 81 to 127, you will hear sample B.

Multi	Zone	Pitch	Filter	Sample
EDIT: SAMPLE				
Sound Name:		MadSnare1		
	Vol	Pan	-Vel-	Pitch
MadSnare1	127	C	01 127	0
MadSnare1	127	C	01 127	0
MadSnare1	127	C	01 127	0
MadSnare1	127	C	01 127	0

## KIT MODE - ADVANCED

### ADJUSTING EQ AND ADDING EFFECTS

- 1 Press the KIT button and select a kit you'd like to edit the EQ or effects of.
2. Press the FX button to open the Effects Menu.
3. Using the faders, you may adjust the high and low EQ of the kit.
4. Access the Reverb and Compression pages using the F-Keys.
5. Press the SAVE button to save the EQ and Effects settings to a User Kit (see Saving a Kit).

Parameter	Definition	Notes
EQ High	EQ high-shelf gain	Increases or decreases the high (treble) frequencies of the drum kit
EQ Low	EQ low-shelf gain	Increases or decreases the low (bass) frequencies of the drum kit
RevProg	Reverb Program	Change the reverb program from a concert hall to a small room, etc.
RevLevel	Reverb Level	This is the overall level of the reverb effect. If there is too much or too little reverb, you can change this one setting instead of each individual reverb send level.
Decay	Reverb Decay	Change how quickly the reverb effect dissipates. Note that Reverb Level needs to be turned up to hear the effect.
CompProg	Compressor Program	This chooses one of the compressor presets to change the sound of that effect. "Kit" selects the settings saved in that Preset Kit, if any. "Off" disables the compressor.
CompThr	Compressor Threshold	The Compressor Threshold is the level where the compressor takes effect. If this setting is high, you won't hear much effect. As you turn this lower, you will hear more compression.
Ratio	Compressor Ratio	Determine the level at which the compressor begins to take effect.

## KIT MODE - ADVANCED

### EDITING THE KIT MIX

1. Press the KIT button and select a Kit you'd like to edit the mix of.
2. Press the MIX button to open Mix Mode.
3. Using the faders, adjust the level of each pad. Use the right two F-Keys to page through to other pads.
4. Edit Pan and Send by selecting their respective pages using their corresponding F-Keys and using the faders to adjust values.
5. Press the SAVE button to save the assignment to a User Kit (see Saving a Kit).

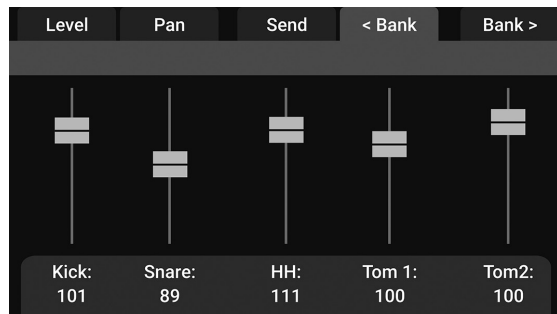

Parameter	Notes
Level	Level controls the volume of the each pad drum sound. The maximum value is 127. Changing the value to 0 effectively mutes the pad.
Pan	Pan controls the left-to-right placement of a sound in the stereo output. Center pan (64) sends the sound equally to both speakers, while adjusting left (<64) or right (>64) shifts the sound toward one side.
Send	Send controls the amount that the effects selected in the FX menu apply to each drum pad. This parameter will not be audible if no effect is turned on. A send value of 0 will remove all effects from the specific pad.

# KIT MODE - ADVANCED

## SAVING AND NAMING A KIT

1. Select and edit a Kit.
2. Press the SAVE button.
3. Use the value knob or +/- buttons to select the User Kit to save over. (You can't write over the Preset drum Kits)
4. Press the F-Key above "Edit Name" to change the name of the saved Kit. The value knob and +/- buttons change the letter, and the cursor knob will change which letter is selected. Press the F-Key above "Save" to confirm and return to Kit Mode.
5. If the default Kit name is selected, press the F-Key above "Yes" to confirm and return to Kit Mode.
6. Press SAVE one last time to write the Kit. The display will read "Saved" and then return to Kit Mode.

## FACTORY RESET

If you ever want to return all settings to the defaults from when the kit was new, or if the module starts acting strangely, a reset may fix this issue.

1. Switch the module off.
2. Hold both +/- buttons.
3. Switch the module on. The screen will read "FactoryReset" and all Settings will return to their defaults. Any changes to trigger Settings, User Kits, etc. will be lost.



## SONG MODE

### PLAYING A SONG

1. Press SONG, select a song number, then PLAY to play a song.
2. Press the PLAY button to stop playback of the song.

*NOTE: You can temporarily change the tempo of a song while playback is in progress. The song returns to its preset tempo when a different song is selected.*

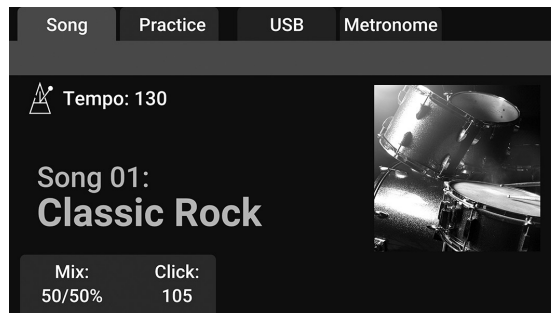

### MUTING THE DRUM PART

1. Press the MUTE button to mute the track drum part of the song. The screen will display "Drums Muted."
2. Press the MUTE button again to unmute the track drum part.
3. To unmute the drums, press MUTE again.

### CHANGING THE DRUM MIX

After muting the drum part in the step above, you can change the balance between your drum sounds and the backing track with the MIX button.

1. While in Song mode, use the faders to adjust the mix between your drum sounds and backing track, and the volume of the click track.
2. Press the +/- buttons to change the balance between the drums and the accompaniment (guitar and bass).

### CHANGING THE TEMPO OF A SONG

1. Press the SONG button. The current song will be displayed.
2. Press PLAY to start song playback.
3. Press the TEMPO button and use the value knob or +/- buttons to adjust the tempo of the song. You can also press the TEMPO button to the rhythm you want to play and it will automatically set the tempo.

*NOTE: The song sounds best at its default tempo.*

### COPYING A SONG

You can copy a Preset Song to a User Song, then replace the drum track.

1. Select a Song.
2. Press the SAVE button to save it as a User Song.
3. Press the -/+ buttons to choose the User Song to save to.
4. Press the SAVE button to rename the User Song slot.
5. Press the EDIT button to move the cursor.
6. Press +/- to change the character.
7. Press the SAVE button one more time to save the song to a User location.

*NOTE: If you want to rename a User Song, save the song to the same position, then use the rename instructions.*

## RECORDING A SONG

### TO RECORD

1. Press the REC button.
2. Use the F-Keys to select whether to record/play as MIDI or to playback an AUDIO file from a connected USB device. AUDIO cannot be selected if no USB device is connected.
3. In MIDI Mode, you may selected whether to Play to, Record over or Export to USB User Songs using the F-Keys. Adjust the tempo using the TEMPO button and value knob or +/- buttons. Adjust the mix and click using the corresponding faders.
4. In AUDIO mode, you may also select whether to Play to, Record over or Export to USB User Songs using the F-Keys, PLAY and REC button. Adjust the volume of a playback using the F-keys and use the faders to edit the mix and click volume. You may select whether to record audio as an .mp3 file or .wav file in the Setup Menu.

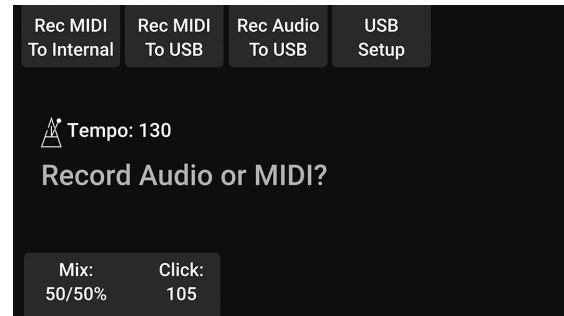

## PRACTICE MODE

To enter Practice Mode, press the SONG button and use the F-Key labeled Practice.

The Practice display on the bottom of the display shows how close you are to playing exactly on the beat. In this example, the player was slightly early in their playing, so the display shows just left of center. If the drummer was behind the beat (late), the lit up circle would land on the right side of that display. The display is only active for the quarter-note downbeat on kick and snare. If you are 100% accurate for that quarter-note beat timing, the center circle will light up each time. Playing at 99% will light the circle to the left, and 101% would light the circle to the right.

As the difficulty moves up, you need to be even more accurate. 99.5% accuracy would be enough to trigger the next circle down instead of the center circle.

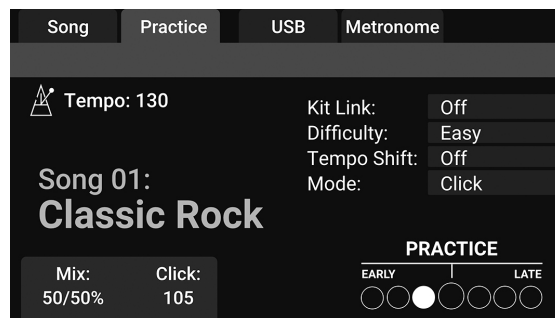

### TO USE PRACTICE MODE:

1. Press the SONG button and use the F-Keys to enter Practice Mode.
2. Use the value knob or the +/- buttons to select one of the Practice Songs.
3. Use the cursor knob and value knob or +/- buttons to adjust other parameters of Practice Mode.
4. Press PLAY. There will be a 1-bar intro that plays the drum beat along with the click. Then the drum part stops, and it starts listening for your playing. Practice Mode listens only on the quarter note beat. Each beat is scored using the Practice Meter.
5. Every four bars, the "Level" number indicator gives an average accuracy score like "82%."
6. When finished, press the PLAY button again. The final percentage and score is shown, like: ("for instance, Score: 2105"). The score is weighted to consider which exercise is selected, the difficulty, the starting tempo and whether Tempo Shift is on or off.

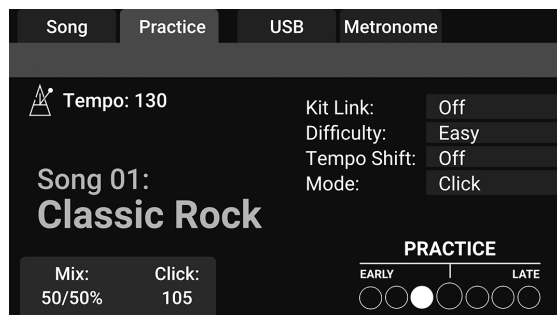

### PRACTICE MODE EDIT

When in Practice Mode, the following parameters may be edited:

- Difficulty (Easy, Medium, Hard): This setting decreases the timing range that is acceptable for being played "on time."
- Tempo Shift (On/Off): When this is switched on, the tempo will accelerate in the fourth bar of the cycle, then the tempo will be +20 bpm for the next three bars. Then it will accelerate again, landing on another tempo that is +20 bpm for the next three bars. The cycle goes: regular tempo, +20, +20, -20, -20 (regular tempo), -20, -20, +20, then repeats.
- Kit Link (On/Off): When Kit Link is set to Off, the kit you were last using in Kit mode will also be used in Practice mode. When Kit Link is set to On, Practice mode will automatically load a preset kit that matches the genre of the selected song.

## PRACTICE MODE

### TO SELECT BETWEEN THE 6 PRACTICE MODES:

1. Click: Play along with the band and the click.
2. NoClick: Play along with the band but no click.
3. NoClick3/1: Play along with the song. The click will play  
     1-bar count in                      Click plays for three bars, silent for one bar, then repeats



4. NoClick1/1: The click will play for one bar, then the click and band will be silent for one bar.
5. NoClick1/3B: The backing track and click will play for one bar, then the click and band will be silent for one bar. On bar three, only the bass part will come back. Then it will be silent for one more bar and then repeat to the beginning.
6. NoClick1/3: The band and click play for 1 bar. Then there are three bars of silence and then it repeats.

Use the faders to adjust the balance between your drums and the "band" backing you up and the volume of the click track.

## SETUP MODE

The Setup Menu is for changing triggers, MIDI parameters, Hi-Hat values, Bluetooth and power settings. The velocity of the last played note can be viewed in this menu.

### TRIGGER SETTINGS

Adjust trigger settings of each pad in Setup Mode. Select the pad you'd like to adjust the trigger settings of by hitting the physical pad or using the cursor buttons to highlight the pad type and using the value knob or +/- buttons. You may adjust Sensitivity, Retrigger, Threshold, Curve and Ratio in this menu.

Pressing the PLAY button in the menu opens the X-Talk menu, which can be used to reduce the effect of inadvertent vibration triggering other pads.

<p>Sensitivity (each pad input) This control changes the input level of the trigger. Turn this level lower, and it will take more force to play the drum at its highest dynamic. Turn it higher, and it will take less force to play the highest dynamic.</p>
<p>Retrigger (each pad input) This controls how quickly you can play on a pad. If you find that you are playing fast and some drum hits are being missed, turn this down. If you hear double-triggers when you only hit the pad once, turn this value up.</p>
<p>Threshold (each pad input) This controls how softly you can play on a pad. If very soft hits aren't being picked up, turn this control down. If you are hearing false triggers (you played a different pad but heard this one), try turning this up.</p>
<p>Curve (each pad input) This changes the way dynamics work on the pad. "Normal" is the default setting. For a bigger change from soft to loud, try "Dyn" (dynamic). To make the kit easier to play, use "Easy" or "Fixed."</p>
<p>Ratio (each pad input) This adjusts the dynamic range of the pad. Higher ratios reduce dynamic range by making soft hits louder, while lower ratios preserve more natural dynamics.</p>
<p>X-Talk (crosstalk, each pad input) When two pads are mounted on the same stand, the vibration produced by hitting one pad may trigger the sound from another pad unintentionally. This is called crosstalk. You can avoid this problem by adjusting Crosstalk Cancel on the pad that is sounding inadvertently. If the value is set too high, then when two pads are played simultaneously, the one that is struck less forcefully will not sound. Be careful when setting this parameter to the minimum value required to prevent crosstalk. You may calibrate the crosstalk value by selecting the Auto X-talk Mode in the menu, selecting pad that is mistripping and lightly hitting the pad that is causing the trigger.</p>

# SETUP MODE

## MIDI PARAMETERS

<p><b>MIDI Note Number (each pad zone)</b> When using the drum module with another sound source such as a DAW plug-in, each pad you play sends a MIDI note. The default note numbers follow the General MIDI standard for drum sounds. If your software requires different notes or note numbers, you can change them here. Play a pad then press +/- to change to a different note value. The Titan 90 sends and receives on MIDI channel 10. See the next section, "MIDI Note Defaults" for the preset note numbers.</p>
<p><b>Click</b> This parameter determines the time signature the click will play to.</p>
<p><b>ClickRec (Click in Record)</b> Switch this parameter on if you want to hear the metronome while recording. By default, you hear four clicks and then no other accompaniment while recording a song. When you set this to On, the click sound will continue during recording.</p>
<p><b>Local (MIDI Local Control)</b> When using the TITAN 90 with a DAW, recording MIDI and playing it back to the module, you might want to disable the sounds from the pads. Local On is the default, playing the pads plays the drum sounds. Switch to Local Off if you want to play the pads into a DAW, out of the DAW and then back into the sound module for MIDI sequencing.</p>
<p><b>Backup</b> Press the + button to back up your module's global settings by sending MIDI SYSEX to your computer.</p>

## HI-HAT

The Titan 90 hi-hat module works with most standard hi-hat stands. Since stands differ in height, tension and travel, adjusting this menu setting is recommended for the most accurate hi-hat response. The bar next to the hi-hat diagram displays the height value the sensor is reading based on pedal position.

<p><b>Top &amp; Bottom</b> These values determine the pedal positions required to trigger fully open and fully closed hi-hat sounds. The Top value should be set lower than the value shown on the adjacent bar when the hi-hat pedal is completely released (open position). The Bottom value should be set higher than the value shown on the adjacent bar when the pedal is fully pressed down (closed position). These values can be automatically calibrated by pressing the PLAY button in this menu. You will be prompted to fully release the pedal and then fully close it to complete calibration.</p>
<p><b>Pedal Curve</b> This parameter sets how hi-hat sounds transition between open and closed positions. Available options include Normal (default), Dynamic, Easy and Fixed, allowing you to choose the response that feels most natural for your playing style.</p>
<p><b>Splash Sens</b> This value adjusts how easily a hi-hat splash sound is triggered when the pedal is closed and quickly reopened. Higher values make splash sounds easier to trigger, while lower values require more precise pedal movement.</p>

# SETUP MODE

## UTILITY

<p><b>AutoPwr (Auto Power off)</b> If you would like the drum set to power off when it hasn't been played for an hour, turn on AutoPwr. The default setting is off, the Drum Kit will stay on until you press the power button to switch it off.</p>
<p><b>Back Module to USB</b> If you would like to save the settings of your module to a USB, select Send and press PLAY to upload a backup file. To configure your module to the settings of a previously saved state, select Get and press PLAY to download to the module.</p>
<p><b>Record Button Function</b> When pressing the Record button, if you prefer to immediately record audio or MIDI, you may select either parameter. Otherwise, selecting Ask will prompt you to select Audio or MIDI every time Record is pressed.</p>
<p><b>Audio Record Format</b> Determine whether recorded audio is saved as a .mp3 or .wav file format.</p>
<p><b>EXP1 and EXP2 Pad</b> Additional pads may be connected to the Titan 90 module using the dual-zone EXP1 and EXP2 ports on the back panel. Toggle between "Tom" and "Crash" for each port. The "Tom" setting is ideal when using a dual-zone drum pad, while the "Crash" setting is compatible with choke sensors.</p>
<p><b>Zone Intelligence</b> The Titan 90 snare pad detects where you strike the pad and triggers different sounds based on hit location. When Zone Intelligence is Normal, different samples will play depending on where the pad is hit. You can turn this feature off if you want the same sound to play across the entire pad or if triggering an external sound source. You can also select Center Smaller to reduce the size of the center zone, which makes the sound change sooner as you move away from the middle of the pad.</p>

If you change the trigger or other settings and want to go back to the factory default settings, you can always reset your module by holding the +/- buttons while powering it on. You will see "Factory Reset" on the display and all settings will be wiped and returned to the defaults.

# SETUP MODE

## MIDI NOTE DEFAULTS

The Titan 90 default note numbers are shown below. You can change these note number assignments, please check the previous section for instructions.

MIDI Note	Pad
36	Kick
38	Snare - Center
87	Snare - Zone 2
88	Snare - Zone 3
40	Snare - Rimshot
42	Hi Hat - Closed Bow
86	Hi Hat - Semi-open Bow
46	Hi Hat - Open Bow
22	Hi Hat - Closed Edge
24	Hi Hat - Semi-open Edge
26	Hi Hat - Open Edge
60	Hi Hat - Bell
44	Hi Hat - Pedal
85	Hi Hat - Splash
48	Tom 1 Center
50	Tom 1 Rim
45	Tom 2 Center
47	Tom 2 Rim

MIDI Note	Pad
43	Tom 3 Center
58	Tom 3 Rim
41	Tom 4 Center
39	Tom 4 Rim
49	Crash 1 Bow
55	Crash 1 Edge
61	Crash 1 Bell
57	Crash 2 Bow
52	Crash 2 Edge
62	Crash 2 Bell
51	Ride Bow
59	Ride Edge
53	Ride Bell
77	EXP1 Center
79	EXP1 Rim
78	EXP2 Center
80	EXP2 Rim

## HI-HAT MIDI SETTINGS

The Titan 90 Hi-Hat sends MIDI controller 4 information when the hi-hat pedal is moved up and down. If your MIDI sound source or plug-in doesn't have a note value for "Half-Open Hi-Hat," change that note value to the same note number you're using for open hi-hat.

## USB OPERATIONS

The TITAN 90 Module will show up to your computer and devices as a 2-in, 2-out audio interface, and also as a USB MIDI interface. Both are class-compliant for macOS and Windows computers—no driver is required. Just plug it into your computer and your DAW software should recognize the device.

You might need to set up the TITAN 90 as a new MIDI device in your DAW software before it can be used. Refer to your DAW software documentation to do this.

The TITAN 90 also works as a USB host for devices like an iPad. Plug the iPad into the TITAN 90's USB jack using a USB cable and/or adapter, and the iPad's audio will come through the TITAN 90's line and headphone outputs. MIDI will also play into and out of the USB jack. This is great for playing along with music or using educational apps.

## BLUETOOTH

The Titan 90 works with both Bluetooth MIDI and audio. Bluetooth MIDI is often used for apps, like the Simmons Drums app for iOS. Bluetooth Audio allows you to play music from your phone or tablet into the Titan 90, and that sound will come through the line outputs and headphone outputs. The Titan 90 module is always listening for a Bluetooth connection. Simply use your phone or tablet to connect. When a Bluetooth connection is active, the Bluetooth LED on the front panel and the indicator in the display will turn on. The Titan 90 module defaults to having Bluetooth on but can be toggled off in the Setup Menu. Simply use your phone or tablet to connect. When a Bluetooth connection is active, the Bluetooth LED on the front panel and the indicator in the display will turn on. The connection can be confirmed in the Setup Menu.

*NOTE: Because the low bandwidth in Bluetooth, you can only use Bluetooth audio or Bluetooth MIDI—not both at once. If you need both MIDI and Bluetooth connections, you need to use a USB connection with your device.*

### BLUETOOTH WIRELESS MIDI

The Titan 90 includes Bluetooth wireless MIDI for connection to apps like the Simmons Drums 2 app for iOS and Android. To connect the drum module to your tablet or smartphone, open the Bluetooth MIDI settings in your app and select the Titan 90. The Bluetooth indicator on the front panel should light up when connected.

### BLUETOOTH WIRELESS AUDIO

The Titan 90 can also operate as a Bluetooth audio receiver. To send sound through the module's line out and headphone out, simply choose the Titan 90 device from your smartphone, tablet or computer. Again, both the Bluetooth indicator on the front panel will light up when connected.

*NOTE: When both Bluetooth audio and Bluetooth MIDI are connected, there will be longer latency delay compared to using one or the other.*

### SIMMONS DRUMS 2 APP FOR IOS AND ANDROID

Simmons provides a free app for iOS and Android devices to help you select, edit and mix your drum kits. There's even a sampling function that records audio from the microphone to be loaded into the module for playback. Visit [simmonsdrums.net](http://simmonsdrums.net) to learn more.



Simmons Drums 2 App

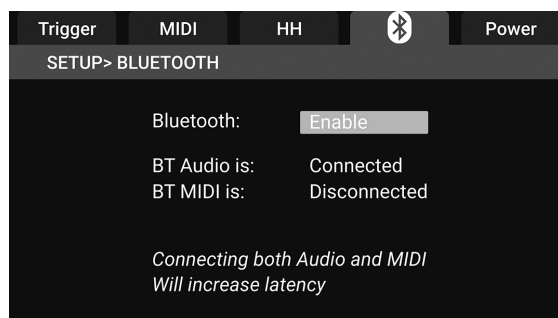

## APPENDIX

## SOUND LIST

Category	Sound #	Sound Name
Kick	1	TamIm 14x24"
Kick	2	Lud74 22"
Kick	3	TamSSC 18x22"
Kick	4	GrtBC 16x22"
Kick	5	YamAbsMpl 18"
Kick	6	TamStar Prog
Kick	7	YamRecCust 22"
Kick	8	TamaSC 22" Lo
Kick	9	DMaple 22x18"
Kick	10	GrtBklyn 22"
Kick	11	PerlRef 22"
Kick	12	GrtRB 20"
Kick	13	TamaSC 22"
Kick	14	GrtBC+Room
Kick	15	Lud74 22" Damp
Kick	16	PerlRef 22" Hi
Kick	17	TamIm 14x24" Damp
Kick	18	TamSSC SC 22" Lyr
Kick	19	YamRecCust 22" Layer
Kick	20	TamStar ProgPitch
Kick	21	YamAbsMpl 18" Hi
Kick	22	TamStar ProgDamp
Kick	23	Hip-Hop Kick
Kick	24	80s Gated Kick
Snare	25	LudCOB C
Snare	26	LudCOB Z2
Snare	27	LudCOB Z3
Snare	28	LudCOB RS
Snare	29	PrICstBr C
Snare	30	PrICstBr Z2
Snare	31	PrICstBr Z3
Snare	32	PrICstBr RS
Snare	33	PrIMWBirch C
Snare	34	PrIMWBirch Z2
Snare	35	PrIMWBirch Z3

## SOUND LIST

Category	Sound #	Sound Name
Snare	36	PrIMWBirch RS
Snare	37	JnkFbr C
Snare	38	JnkFbr Z2
Snare	39	JnkFbr Z3
Snare	40	JnkFbr RS
Snare	41	KepSS C
Snare	42	KepSS Z2
Snare	43	KepSS Z3
Snare	44	KepSS RS
Snare	45	Hvland C
Snare	46	Hvland Z2
Snare	47	Hvland Z3
Snare	48	Hvland RS
Snare	49	GrtPhBz C
Snare	50	GrtPhBz Z2
Snare	51	GrtPhBz Z3
Snare	52	GrtPhBz RS
Snare	53	GrtBIBr C
Snare	54	GrtBIBr Z2
Snare	55	GrtBIBr Z3
Snare	56	GrtBIBr RS
Snare	57	BkwdCop C
Snare	58	BkwdCop Z2
Snare	59	BkwdCop Z3
Snare	60	BkwdCop RS
Snare	61	LudBB C
Snare	62	LudBB Z2
Snare	63	LudBB Z3
Snare	64	LudBB RS
Snare	65	TamDynBr C
Snare	66	TamDynBr Z2
Snare	67	TamDynBr Z3
Snare	68	TamDynBr RS
Snare	69	TamSPCLo C
Snare	70	TamSPCLo Z2

## APPENDIX

## SOUND LIST

Category	Sound #	Sound Name
Snare	71	TamSPCLo Z3
Snare	72	TamSPCLo RS
Snare	73	PrIPicc C
Snare	74	PrIPicc Z2
Snare	75	PrIPicc Z3
Snare	76	PrIPicc RS
Snare	77	AVH Snare C
Snare	78	AVH Snare Z2
Snare	79	AVH Snare Z3
Snare	80	AVH Snare RS
Snare	81	14x5" Gtd Center
Snare	82	14x5" Gtd Z2
Snare	83	14x5" Gtd Z3
Snare	84	14x5" Gtd RS
Snare	85	14x5" Gtd CS
Snare	86	BkwdCop CS
Snare	87	GrTBb C Low
Snare	88	GrTBb Z2 Low
Snare	89	GrTBb Z3 Low
Snare	90	GrTBb RS Low
Snare	91	GrTBrkln C
Snare	92	GrTBrkln Z2
Snare	93	GrTBrkln Z3
Snare	94	GrTBrkln RS
Snare	95	GrTPhbz CS/RS
Snare	96	GrTBrkln C Hi Damp
Snare	97	GrTBrkln Z2 Hi Damp
Snare	98	GrTBrkln Z3 Hi Damp
Snare	99	GrTBrkln C Lo Damp
Snare	100	GrTBrkln Z2 Lo Damp
Snare	101	GrTBrkln Z3 Lo Damp
Snare	102	GrTBrkln RS Hi Damp
Snare	103	GrTBrkln RS Hi
Snare	104	GrTBrkln RS Lo Damp
Snare	105	Jk+Room C

## SOUND LIST

Category	Sound #	Sound Name
Snare	106	Jk+Room Z2
Snare	107	Jk+Room Z3
Snare	108	Jk+Room RS
Snare	109	Hvland C Hi Damp
Snare	110	Hvland Z2 Hi Damp
Snare	111	Hvland Z3 Hi Damp
Snare	112	Hvland RS Hi Damp
Snare	113	LudCOB C Lo Damp
Snare	114	LudCOB Z2 Lo Damp
Snare	115	LudCOB Z3 Lo Damp
Snare	116	LudCOB RS Lo Damp
Snare	117	LudCOB C Hi
Snare	118	LudCOB RS Hi
Snare	119	PrICstBr C Damp
Snare	120	PrICstBr Z2 Damp
Snare	121	PrICstBr Z3 Damp
Snare	122	PrICstBr RS Damp
Snare	123	LudCOB Z2 Dmp
Snare	124	LudCOB Z3 Dmp
Snare	125	LudCOB Z2 Lo
Snare	126	LudCOB Z3 Lo
Snare	127	PrICstBr C Hi Damp
Snare	128	PrICstBr Z2 Hi Damp
Snare	129	PrICstBr Z3 Hi Damp
Snare	130	PrICstBr RS Lo Damp
Snare	131	PrICstBr C Lo Damp
Snare	132	PrICstBr Z2 Lo Damp
Snare	133	PrICstBr Z3 Lo Damp
Snare	134	PrICstBr CS
Snare	135	PnkRing C
Snare	136	PnkRing Z2
Snare	137	PnkRing Z3
Snare	138	PnkRing RS
Snare	139	LudBB C Hi
Snare	140	LudBB Z2 Hi

## APPENDIX

## SOUND LIST

Category	Sound #	Sound Name
Snare	141	LudBB Z3 Hi
Snare	142	LudBB RS Hi
Snare	143	LudBB C Damp
Snare	144	LudBB Z2 Damp
Snare	145	LudBB RS Damp
Snare	146	GrtBrkln C Hi
Snare	147	GrtPhBz C Hi Damp
Snare	148	GrtPhBz Z2 Hi Damp
Snare	149	GrtBrkln C Verb
Snare	150	GrtBrkln Z2 Verb
Snare	151	GrtBrkln Z3 Verb
Snare	152	GrtBrkln RS Verb
Snare	153	KepSS C Layer
Snare	154	KepSS Z2 Layer
Snare	155	KepSS Z3 Layer
Snare	156	KepSS RS Layer
Snare	157	PrnCstBr C Layer
Snare	158	PrnCstBr Z2 Layer
Snare	159	PrnCstBr Z3 Layer
Snare	160	PrnCstBr RS Layer
Snare	161	TamStarNoise C
Snare	162	TamStarNoise Z2
Snare	163	TamStarNoise Z3
Snare	164	TamStarNoise RS
Snare	165	TamSPCLo C Damp
Snare	166	TamSPCLo Z2 Damp
Snare	167	TamSPCLo Z3 Damp
Snare	168	TamSPCLo RS Damp
Snare	169	TamSPCLo C Hi
Snare	170	TamSPCLo Z2 Hi
Snare	171	TamSPCLo Z3 Hi
Snare	172	TamSPCLo RS Hi
Tom	173	TamImp 13"
Tom	174	TamImp 16"
Tom	175	TamImp 18"

## SOUND LIST

Category	Sound #	Sound Name
Tom	176	TamImp 20"
Tom	177	PrIRef 10"
Tom	178	PrIRef 11"
Tom	179	PrIRef 12"
Tom	180	PrIRef 13"
Tom	181	PrIRef 16"
Tom	182	PrIRef 18"
Tom	183	PrIRef 9"
Tom	184	LudMpl 12"
Tom	185	LudMpl 14"
Tom	186	LudMpl 16"
Tom	187	LudMpl 18"
Tom	188	TamSC Metal 12"
Tom	189	TamSC Metal 14"
Tom	190	TamSC Metal 16"
Tom	191	TamSC Metal 18"
Tom	192	TamSSC 10"
Tom	193	TamSSC 12"
Tom	194	TamSSC 14"
Tom	195	TamSSC 16"
Tom	196	TamStar Prog 10"
Tom	197	TamStar Prog 12"
Tom	198	TamStar Prog 16"
Tom	199	TamStar Prog 18"
Tom	200	YamAbsMaple 12"
Tom	201	YamAbsMaple 13"
Tom	202	YamAbsMaple 14"
Tom	203	YamAbsMaple 15"
Tom	204	YamAbsMaple 16"
Tom	205	YamAbsMaple 17"
Tom	206	YamAbsMaple 18"
Tom	207	YamAbsMaple 20"
Tom	208	YamRecCst 10"
Tom	209	YamRecCst 12"
Tom	210	YamRecCst 14"

## APPENDIX

## SOUND LIST

Category	Sound #	Sound Name
Tom	211	YamRecCst 16"
Tom	212	GrtrBrkln 10"
Tom	213	GrtrBrkln 12"
Tom	214	GrtrBrkln 14"
Tom	215	GrtrBrkln 16"
Tom	216	GrtrRB 13"
Tom	217	GrtrRB 14"
Tom	218	GrtrRB 16"
Tom	219	GrtrRB 18"
Tom	220	GtrBC 13"
Tom	221	DMaple 10"
Tom	222	DMaple 12"
Tom	223	DMaple 14"
Tom	224	DMaple 16"
Tom	225	GrtrBC 12"
Tom	226	GrtrBC 14"
Tom	227	GrtrBC 16"
Tom	228	LudMpl 12" Damp
Tom	229	LudMpl 14" Damp
Tom	230	LudMpl 16" Damp
Tom	231	LudMpl 18" Damp
Tom	232	TamImp 13" Damp
Tom	233	TamImp 16" Damp
Tom	234	TamImp 18" Damp
Tom	235	TamImp 20" Damp
Tom	236	TamSSC 10" Damp
Tom	237	TamSSC 12" Damp
Tom	238	TamSSC 14" Damp
Tom	239	TamSSC 16" Damp
Tom	240	TamStar Prg 10" LDamp
Tom	241	TamStar Prg 12" LDamp
Tom	242	TamStar Prg 16" LDamp
Tom	243	TamStar Prg 18" LDamp
Tom	244	DMaple 10" Damp
Tom	245	DMaple 12" Damp

## SOUND LIST

Category	Sound #	Sound Name
Tom	246	DMaple 14" Damp
Tom	247	DMaple 16" Damp
Tom	248	80sGate-Hi
Tom	249	80sGate-Mid
Tom	250	80sGate-Low
Tom	251	80sGate-XL
Tom	252	TamStar Prg 10" Pitch
Tom	253	TamStar Prg 12" Pitch
Tom	254	TamStar Prg 16" Pitch
Tom	255	TamStar Prg 18" Pitch
Tom	256	TamStar Prog 10" Damp
Tom	257	TamStar Prog 12" Damp
Tom	258	TamStar Prog 16" Damp
Tom	259	TamStar Prog 18" Damp
Tom	260	YamAbsMaple 12" Damp
Tom	261	YamAbsMaple 14" Damp
Tom	262	YamAbsMaple 16" Damp
Tom	263	YamAbsMaple 18" Damp
Tom	264	YamAbsMaple 8"
Tom	265	YamRecCst 10" Damp
Tom	266	YamRecCst 12" Damp
Tom	267	YamRecCst 14" Damp
Tom	268	YamRecCst 16" Damp
Tom	269	YamAbsMaple 10" Damp
Tom	270	Tom Rim Hi1
Tom	271	Tom Rim Hi2
Tom	272	Tom Rim Hi3
Tom	273	Tom Rim Hi4
Tom	274	Tom Rim Hi5
Tom	275	Tom Rim Lo1
Tom	276	Tom Rim Lo2
Tom	277	Tom Rim Lo3
Tom	278	Tom Rim Lo4
Tom	279	Tom Rim Mid1
Tom	280	Tom Rim Mid2

## APPENDIX

## SOUND LIST

Category	Sound #	Sound Name
Tom	281	Tom Rim Mid3
Tom	282	Tom Rim Mid4
Tom	283	Tom Rim Mid5
Hi-Hat	284	Past602 14" Bow Cl
Hi-Hat	285	Past602 14" Bow Op
Hi-Hat	286	Past602 14" Bow HO
Hi-Hat	287	Past602 14" Edge Cl
Hi-Hat	288	Past602 14" Edge Op
Hi-Hat	289	Past602 14" Edge HO
Hi-Hat	290	Past602 14" Foot
Hi-Hat	291	Past602 14" Splash
Hi-Hat	292	Past602 14" Bell
Hi-Hat	293	IstXt 14" Bow Cl
Hi-Hat	294	IstXt 14" Bow Op
Hi-Hat	295	IstXt 14" Bow HO
Hi-Hat	296	IstXt 14" Edge Cl
Hi-Hat	297	IstXt 14" Edge HO
Hi-Hat	298	IstXt 14" Edge Op
Hi-Hat	299	IstXt 14" Foot
Hi-Hat	300	IstXt 14" Splash
Hi-Hat	301	IstXt 14" Bell
Hi-Hat	302	PstRude 14" Bow Cl
Hi-Hat	303	PstRude 14" Bow HO
Hi-Hat	304	PstRude 14" Bow Op
Hi-Hat	305	PstRude 14" Edge Cl
Hi-Hat	306	PstRude 14" Edge HO
Hi-Hat	307	PstRude 14" Edge Op
Hi-Hat	308	PstRude 14" Foot
Hi-Hat	309	PstRude 14" Splash
Hi-Hat	310	PstRude 14" Bell
Hi-Hat	311	Zil50s 13" Bow Cl
Hi-Hat	312	Zil50s 13" Bow HO
Hi-Hat	313	Zil50s 13" Bow Op
Hi-Hat	314	Zil50s 13" Edge Cl
Hi-Hat	315	Zil50s 13" Edge HO

## SOUND LIST

Category	Sound #	Sound Name
Hi-Hat	316	Zil50s 13" Edge Op
Hi-Hat	317	Zil50s 13" Foot
Hi-Hat	318	Zil50s 13" Splash
Hi-Hat	319	Zil50s 13" Bell
Crash	320	ZilAThin 19" Bell
Crash	321	ZilAThin 19" Bow
Crash	322	ZilAThin 19" Crash
Crash	323	ZilChina 18" Bow
Crash	324	ZilChina 18" Crash
Crash	325	SbExpl 18" Bell
Crash	326	SbExpl 18" Bow
Crash	327	SbExpl 18" Crash
Crash	328	PaistFlICr 16" Bell
Crash	329	PaistFlICr 16" Bow
Crash	330	PaistFlICr 16" Crash
Crash	331	IstXstB 17" Bell
Crash	332	IstXstB 17" Bow
Crash	333	IstXstB 17" Crash
Crash	334	IstXist 19" Bell
Crash	335	IstXist 19" Bow
Crash	336	IstXist 19" Crash
Crash	337	ZilA 18" Bell
Crash	338	ZilA 18" Bow
Crash	339	ZilA 18" Crash
Crash	340	ZilA 20" Bell
Crash	341	ZilA 20" Bow
Crash	342	ZilA 20" Crash
Crash	343	ZilK Dark 20" Bell
Crash	344	ZilK Dark 20" Bow
Crash	345	ZilK Dark 20" Crash
Crash	346	ZilChina 22" Bow
Crash	347	ZilChina 22" Crash
Crash	348	ZilKSw 17" Bell
Crash	349	ZilKSw 17" Bow
Crash	350	ZilKSw 17" Crash

## APPENDIX

## SOUND LIST

Category	Sound #	Sound Name
Crash	351	SabSplash 8" Bow
Crash	352	SabSplash 8" Crash
Crash	353	Stack China
Crash	354	Stack China Low
Crash	355	Stack Splash Crash
Ride	356	ZilKSw 21" Bell
Ride	357	ZilKSw 21" Bow
Ride	358	ZilKSw 21" Crash
Ride	359	IstXst 22" Bell
Ride	360	IstXst 22" Bow
Ride	361	IstXst 22" Crash
Ride	362	IstOM 22" Bell
Ride	363	IstOM 22" Bow
Ride	364	IstOM 22" Crash
Ride	365	IstPwr 22" Bell
Ride	366	IstPwr 22" Bow
Ride	367	IstPwr 22" Crash
Ride	368	MurSizz 20" Bell
Ride	369	MurSizz 20" Bow
Ride	370	MurSizz 20" Crash
Ride	371	ZilKSw 23" Bell
Ride	372	ZilKSw 23" Crash
Ride	373	ZilKSw 23" Bow
Perc	374	Tamborine Room
Perc	375	Shaker
Perc	376	Tamborine Room Lo
Perc	377	Tamborine Slap
Perc	378	Tamborine Snake
Perc	379	Claps Room
Perc	380	Rototom 6"
Perc	381	Rototom 8"
Perc	382	Rototom 10"
Perc	383	Rototom 12
Perc	384	Timpani 1
Perc	385	Timpani 2

## SOUND LIST

Category	Sound #	Sound Name
Perc	386	Wind Chimes
Perc	387	Shaker Hi
Perc	388	Sleighbells
Perc	389	Drumsticks
Latin	390	Cowbell Room
Latin	391	Cowbell Room Low
Latin	392	Cowbell Hi Damp
Latin	393	Cowbell Lo Damp
Latin	394	Cowbell Dry
Latin	395	Conga Open
Latin	396	Conga Slap
Latin	397	Timbale Hi
Latin	398	Timbale Lo
Latin	399	Timbale Lo Side
Latin	400	Tumba Dead Tone
Latin	401	Tumba
Latin	402	Tumba Low
Latin	403	Agogo Hi
Latin	404	Agogo Low
Latin	405	Clave
Latin	406	Cajon
Latin	407	Cantaro
Latin	408	Maraca Shake
Latin	409	Whistle
Latin	410	Clave Lo
Brazil	411	Surdo
Brazil	412	Surdo Low
Brazil	413	Caixa Center
Brazil	414	Caixa Z2
Brazil	415	Caixa Z3
Brazil	416	Caixa Rim
Brazil	417	Tambourn
Brazil	418	Pandero
Africa	419	Africa Shaker
Africa	420	Djembe DeadTone

## APPENDIX

## SOUND LIST

Category	Sound #	Sound Name
Africa	421	Djembe Dun
Africa	422	Djembe OS
Africa	423	Go Bell
Africa	424	Beat Cymbal
Africa	425	Cymbal Stack
Africa	426	Talking Drum Boom
Africa	427	Talking Drum SBoom
Africa	428	Talking Drum Tap
Africa	429	Udu Dum
Africa	430	Udu DumSO
Africa	431	Udu Fngers
Africa	432	Udu Top
Africa	433	Huh
Africa	434	Uhh
Asia	435	Gong
Asia	436	Aapa Kalai 1
Asia	437	Aapa Kalai 2
Asia	438	Tabla DGEE
Asia	439	Tabla DGMK
Asia	440	Tabla DINM
Asia	441	Tabla NAH C
Asia	442	Tabla NAH Z2
Asia	443	Tabla NAH Z3
Asia	444	Gadasing 1
Asia	445	Cadasing Db
Asia	446	Cadasing 2
Asia	447	India Count 1
Asia	448	India Count 2
Mideastern	449	Darbuka
Mideastern	450	Darbka Opn
Mideastern	451	Rig Dume
Mideastern	452	Riq Jingle
Mideastern	453	Finger Cymbal
Mideastern	454	Bendir 1
Mideastern	455	Bendir 2

## SOUND LIST

Category	Sound #	Sound Name
Mideastern	456	Bendir 3
Mideastern	457	Bendir 4
Mideastern	458	Bendir 5
Mideastern	459	Mashar
Mideastern	460	Turkish Loop
Mideastern	461	Turkish Female
Native Amer	462	Deer Skin 1
Native Amer	463	Deer Skin 2
Native Amer	464	Deer Skin 3
Native Amer	465	Horsehide C
Native Amer	466	Horsehide Z2
Native Amer	467	Horsehide Z3
Native Amer	468	Horsehide Drum 2
Native Amer	469	Horsehide Drum 3
Native Amer	470	Metal Shaker
Native Amer	471	Metal Shaker Long
Native Amer	472	PuebloVox 1
Native Amer	473	PuebloVox 2
Native Amer	474	Rainstick
Native Amer	475	Ritual Drum 1
NativeAmer	476	Ritual Drum 2
NativeAmer	477	Sheshone Vox
NativeAmer	478	Sheshone Vox Lo
NativeAmer	479	ZuniVox 1
NativeAmer	480	ZuniVox 2
NativeAmer	481	ZuniVox 3
Found	482	Bell
Found	483	ABS Pipe 1
Found	484	ABS Pipe 2
Found	485	Beer Can
Found	486	Boat Horn
Found	487	Clown Horn
Found	488	Bottle 1
Found	489	Bottle 2
Found	490	Bottle 3

## APPENDIX

## SOUND LIST

Category	Sound #	Sound Name
Found	491	Metal Bucket
Found	492	Pipes 1
Found	493	Pipes 2
Found	494	Pipes 3
Found	495	Nasty TrashCan 1
Found	496	Nasty TrashCan 2
Found	497	Nasty TrashCan 3
Found	498	Plastic Bucket C
Found	499	Plastic Bucket Z2
Found	500	Plastic Bucket Z3
Found	501	Plastic Bucket Mute
Found	502	Plastic Bucket RS
EKick	503	80 Kik Dist
EKick	504	T909 Long
Ekick	505	SDSV Kick
Ekick	506	SDS9 Kick1
Ekick	507	SDX Power Kick
EKick	508	Tekno Kik
Ekick	509	SDS7 LoKick
Ekick	510	MatrixGens
EKick	511	GrtBC Gtr Layer
ESnare	512	90 Snare Layer
ESnare	513	SDS7 HiSnr
ESnare	514	SDS7 AnaSnr
ESnare	515	SDS7 LoSnr C
ESnare	516	SDS7 LoSnr Z2
ESnare	517	SDS9 Sn 1
ESnare	518	SDS9 Sn 3 Center
ESnare	519	SDS9 Sn 3 Z2
ESnare	520	SDS9 Sn 3 Z3
ESnare	521	SDSV HiSnr
ESnare	522	SDSV Snare2
ESnare	523	SDSV Snare5 Center
ESnare	524	SDSV Snare5 Z2
ESnare	525	SDX Snare

## SOUND LIST

Category	Sound #	Sound Name
ESnare	526	SDX Snare +1
ESnare	527	SDX Snare +2
ESnare	528	MetalSn C
ESnare	529	MetalSn Z2
ESnare	530	MetalSn Z3
ESnare	531	MetalSn RS
ESnare	532	HipHop Sn
ESnare	533	HipHop Sn Layer
ESnare	534	RnB Sn
ESnare	535	78 Snare Center
ESnare	536	Tek Snare
ESnare	537	T909 Sn+Cl
ESnare	538	TechnoRS
ESnare	539	T909 Snare C
ESnare	540	T909 Snare Z2
ESnare	541	T909 Snare Z3
ETom	542	SDSV Tom 1
ETom	543	SDSV Tom 2
ETom	544	SDSV Tom 3
ETom	545	SDSV Tom 4
ETom	546	SDSV Tom 5
ETom	547	SDSV Tom 6
ETom	548	SDSV Tom Stereo
ETom	549	SDX Tom 1
ETom	550	SDX Tom 2
ETom	551	SDX Tom 3
ETom	552	SDX Tom 4
ETom	553	SDS7 Tom 1
ETom	554	SDS7 Tom 2
ETom	555	SDS7 Tom 3
ETom	556	SDS7 Tom 4
ETom	557	SDS7 Tom 5
ETom	558	SDS9 Tom 1
ETom	559	SDS9 Tom 2
ETom	560	SDS9 Tom 3

## APPENDIX

## SOUND LIST

Category	Sound #	Sound Name
ETom	561	SDS9 Tom 4
ETom	562	SD Rez™
ETom	563	SD Turn Hi
ETom	564	SD Turn Highest
ETom	565	SD Turn Low
ETom	566	SD Turn Mid
ETom	567	80 Tom Hi
ETom	568	80 Tom Lo
ETom	569	80 Tom Lower
ETom	570	80 Tom Mid
ETom	571	C78 Tom 1
ETom	572	C78 Tom 2
ETom	573	C78 Tom 3
ETom	574	C78 Tom 4
ETom	575	T909 Tom 1
ETom	576	T909 Tom 2
ETom	577	T909 Tom 3
ETom	578	Tekno Tom Hi
ETom	579	Tekno Tom 1
ETom	580	Tekno Tom 2
ETom	581	Tekno Tom 3
ETom	582	Tom Metal 1
ETom	583	Tom Metal 2
ETom	584	Tom Metal 3
ETom	585	Tom Metal 4
EHi-Hat	586	SDS7 HH-Cl
EHi-Hat	587	SDS7 HH-Op
EHi-Hat	588	SDS7 HH-Ft
EHi-Hat	589	SDS7 HH-Fr
EHi-Hat	590	SDSV HH-Cl
EHi-Hat	591	SDSV HH-Ped
EHi-hat	592	SDSV HH-Op
EHi-hat	593	TekHH-Cl
EHi-hat	594	TekHH-Op
ECymbal	595	SDSV Cym 1

## SOUND LIST

Category	Sound #	Sound Name
ECymbal	596	SDSV Cym 2
ECymbal	597	SDSV Cym 3
ECymbal	598	SDSV Cym 4
ECymbal	599	SDSV Cym 5
ECymbal	600	SDSV Cym 6
ECymbal	601	SDSV Cym 7
ECymbal	602	E Cymbal 1
ECymbal	603	E Cymbal 2
ECymbal	604	T909 Crash
ECymbal	605	T909 Ride
ECymbal	606	T909 RidHi
ECymbal	607	T909 RidLo
ECymbal	608	Cymbal 80
ECymbal	609	Cymbal 80 Hi
ECymbal	610	Cymbal C78
ECymbal	611	Cymbal C78 Hi
ECymbal	612	MetalCymb
ECymbal	613	E Hi Hat
ECymbal	614	80 HH Closed
ECymbal	615	80 HH Open
ECymbal	616	HipHop HH Cl
ECymbal	617	RnB HH Cl
ECymbal	618	HipHop HH Op
ECymbal	619	SDS7 Crash
ECymbal	620	SDS7 Cymb2
ECymbal	621	SDS7 Cymb1
ECymbal	622	SDS7 Cymb3
ECymbal	623	SDS7 Cymb4
ECymbal	624	SDS7 Cymb5
EPerc	625	ClapTrap 1
EPerc	626	ClapTrap 2
EPerc	627	Click 80
EPerc	628	Elec Click
EPerc	629	Noise Clap
EPerc	630	Steel Rattle

## APPENDIX

## SOUND LIST

Category	Sound #	Sound Name
EPerc	631	Strike
EPerc	632	NastyKick
EPerc	633	EatBrain
EPerc	634	Pic Animal Center
EPerc	635	Pic Animal Z2
EPerc	636	Pic Animal Z3
EPerc	637	HH Bubb
EPerc	638	DstortRngr
EPerc	639	SSRattle
EPerc	640	BassRatle
EPerc	641	BassRatMid
EPerc	642	BassRatLo
EPerc	643	RnB Stab 1
EPerc	644	RnB Stab 2
EPerc	645	RnB Stab 3
EPerc	646	RnB Stab 4
EPerc	647	Scratch 1
EPerc	648	Scratch 2
EPerc	649	Scratch 3
EPerc	650	Scratch 4
EPerc	651	Scratch 5
EPerc	652	SDSV Clap
EPerc	653	SDX Angkor
EPerc	654	SDX Begone
EPerc	655	SDX Birthright
EPerc	656	SDX Brother
EPerc	657	SDX Evensong
EPerc	658	SDX Masquerade
EPerc	659	SDX Meeting
EPerc	660	SDX Mountain
EPerc	661	SDX Order
EPerc	662	SDX Park Snare
EPerc	663	SDX Pretend
EPerc	664	SDX Reason
EPerc	665	SDX Sunrise

## SOUND LIST

Category	Sound #	Sound Name
EPerc	666	SDX Teakbois
EPerc	667	SDX Universe
EPerc	668	SD Noise
EPerc	669	SD MatrixGen
EPerc	670	SD Tonight Low
EPerc	671	SD Tonight Metal
EPerc	672	SD Tonight Mid

## APPENDIX

## KIT LIST

#	Kit Name
1	Legendary
2	Great Hall
3	Aggressive
4	Heavy Rock
5	Modern Pop
6	Dry Seventies
7	Metallic
8	Baked Potato
9	Americana
10	Yacht Rock
11	High Strung
12	Hitmaker
13	Brooklyn
14	Coachella
15	Big Ballad
16	Punchy Rock
17	Alt Rock
18	Prog Odyssey
19	Alternative
20	Vintage Pump
21	80s Gated
22	Studio A
23	Main Stage
24	Young Punk
25	Triple Scale
26	Shangri-La
27	Heartland
28	Modern Punch
29	Contemporary
30	Late Show
31	Tighten Up
32	Big 80s
33	Maple Pop
34	Compressor
35	Layered Pop

## KIT LIST

#	Kit Name
36	Damped Maple
37	Top 40
38	Modern Metal
39	Deep Drums
40	Empire
41	Thrasher
42	Sunset Strip
43	Wicked
44	Viking Helm
45	High Volume
46	Animal
47	War God
48	Metalstar
49	Diss Track
50	R&B Swing
51	Dreamwave
52	Street Level
53	Funk Booty
54	Hip-Hop
55	Cocktails
56	90s Studio
57	Lounge Gig
58	Roundbadge
59	Modern Jazz
60	Fusion Club
61	Swing Ballad
62	SDX
63	House Rave
64	Nails
65	SDS9
66	Tekno
67	SDS7
68	SDSV
69	Latin
70	India

# APPENDIX

## KIT LIST

#	Kit Name
71	Brazil
72	Street Beat
73	West Africa
74	Native American Kit
75	Mideastern

## SONG LIST

#	Display Name
Song 01	Classic Rock
Song 02	R&B
Song 03	Metal
Song 04	User Song 1
Song 05	User Song 2
Song 06	User Song 3
Song 07	User Song 4
Song 08	User Song 5
Song 09	User Song 6
Song 10	User Song 7



## WARRANTY

### Two (2) Years Limited Warranty

Subject to the limitations set forth below, Simmons hereby represents and warrants that the components of this product shall be free from defects in workmanship and materials, including implied warranties of merchantability or fitness for a particular purpose, subject to normal use and service, for two (2) years to the original owner from the date of purchase.

Retailer and manufacturer shall not be liable for damages based upon inconvenience, loss of use of product, loss of time, interrupted operation or commercial loss or any other incidental or consequential damages including but not limited to lost profits, downtime, goodwill, damage to or replacement of equipment and property, and any costs of recovering, reprogramming or reproducing any program or data stored in equipment that is used with Simmons products. This guarantee gives you specific legal rights. You may have other legal rights which vary from state to state. Some states do not allow limitations on how long an implied warranty lasts, so the above limitation may not apply to you.

Simmons  
P.O. Box 5111 Thousand Oaks, CA 91359-5111

All trademarks and registered trademarks mentioned herein are recognized as the property of their respective holders.

## FCC STATEMENT

1. Caution: Changes or modifications to this unit not expressly approved by the party responsible for compliance could void the user's authority to operate the equipment.

2. Note: This equipment has been tested and found to comply with the limits for a Class B digital device, pursuant to Part 15 of the FCC Rules. These limits are designed to provide reasonable protection against harmful interference in a residential installation. This equipment generates, uses, and can radiate radio frequency energy and, if not installed and used in accordance with the instructions, may cause harmful interference to radio communications. However, there is no guarantee that interference will not occur in a particular installation. If this equipment does cause harmful interference to radio or television reception, which can be determined by turning the equipment off and on, the user is encouraged to try to correct the interference by one or more of the following measures:

- Reorient or relocate the receiving antenna.
- Increase the separation between the equipment and receiver.
- Connect the equipment into an outlet on a different circuit.

### Patent Information

U.S. Patent No. 12,254,856 and other patents pending

**MISSING  
—OR—  
DAMAGED  
PARTS?**

**HAVE QUESTIONS?**

**CALL  
888-621-4008  
TOLL FREE**

**—HAVE—  
ASSEMBLY  
QUESTIONS?**

OR VISIT OUR WEBSITE AT: [SIMMONSDRUMS.NET](http://SIMMONSDRUMS.NET)